

Anacon Systems, Inc.

*Comfort+*TM C1300 Installation and Operation Manual



This manual will show you how to install and use your Anacon Systems variable speed motor controller correctly. Please follow the instructions carefully.

Manufacturer's Warranty

ANACON SYSTEMS warrants, except with respect to unauthorized modification of the Products, that the Products and parts thereof shall be free from defects in material and workmanship under normal use, and will meet the Products' specification for Products and parts which have been properly warehoused, used, installed, or serviced. The foregoing warranty is extended to the Distributor only and is not transferable to subsequent purchasers or users of the Products, but said warranty shall survive the anticipated resale of the Products by the Distributor and further resale by the purchasers of the Distributor. ANACON SYSTEMS shall honor its warranties to the Distributor whether a breach is discovered by the Distributor or a subsequent user of the products.

The foregoing warranty of ANACON SYSTEMS shall expire upon the end of twelve (12) months from date of installation or eighteen (18) months from the receipt of shipment, whichever occurs sooner.

With respect to any Product which does not conform to specification, ANACON SYSTEMS' liability under its warranty shall be limited to issuance of a credit for any such Product, inclusive of freight, which is found to be non-conforming, providing that:

- (i) ANACON SYSTEMS shall be notified of any claim as to breach of warranty as soon as practical after the Distributor learns of the breach; and
- (ii) For warranty claim(s), the Distributor will provide ANACON SYSTEMS a failure report each quarter without charge to ANACON SYSTEMS.

Any repair shall not extend the warranty period, but authorized repair shall not void any Product warranty.

ANACON SYSTEMS warrants that all of the Products sold to the Distributor will be delivered free of any security interest or other lien or encumbrance and that ANACON SYSTEMS will convey to the Distributor good title of such Products. ANACON SYSTEMS further warrants and represents to the Distributor that ANACON SYSTEMS owns all right, title and interest in and to the patents, copyrights, trademarks and other intellectual property necessary to make the transfer contemplated by this Agreement without violating or infringing upon any rights of any third party and without breach of any third-party license to ANACON SYSTEMS, and there is currently no actual or threatened suit by any third party based on an alleged violation, infringement or breach by ANACON SYSTEMS. Use of the Intellectual Property after execution of this Agreement shall not be disturbed or interfered with subject to ANACON SYSTEMS' obligations herein.

Radio Interference

This equipment generates, uses, and can radiate radio frequency energy and, if not installed and used according to the instructions, may cause harmful interference to radio communications. However, there is no guarantee that interference will not occur in a particular installation. If this equipment does cause harmful interference to radio or television reception, which is found by turning the equipment off and on, the user is encouraged to try to correct the interference by one or more of the following measures:

- Reorient or relocate the receiving antenna
- Increase the separation between the equipment and device
- Connect the receiver to an outlet other than the equipment's
- Install optional EMI line filter CORCOM part number 10VK3.
- Consult a dealer or an experienced radio/TV technician for assistance

Safety/Hazards (PLEASE READ THIS SECTION CAREFULLY)

The safety of personnel is of utmost importance to Anacon Systems, Inc. Variable speed drives (also referred to as drives) and associated option units can be hazardous if they are not correctly installed, maintained and operated.

The manufacturer accepts no liability for any consequences resulting from negligence or incorrect installation or adjustment of the equipment or from mismatching the drive with the motor.

The contents of this manual are believed to be correct at the time of printing. In the interest of a policy of continuous development and improvement, the manufacturer reserves the right to change the specification of the drive or its performance, or the contents of this manual without notice.





WARNING! The installer is responsible for complying with all relevant regulations, such as national wiring regulations and accident prevention regulations. Particular attention must be given to the cross-sectional areas of conductors, the selection of fuses or other protection, and protective earth/ground connections.



WARNING! The voltages in the power cables and certain parts of the drive can result in death. Whenever the drive has been used it must be isolated and disconnected for a minimum of 5 minutes

before any work commences. The drive must be connected to the system earth/ground by the earth/ground connection. (See Power Connections)

 **DANGER!** Only qualified electrical personnel familiar with the construction and operation of this equipment and the hazards involved should install, adjust, operate, and/or service this equipment. Read and understand this manual in its entirety before proceeding. Failure to observe this precaution could result in severe bodily injury or loss of life.

 **WARNING!** Drives are intended as components for incorporation into electrical control systems or machines. It is the responsibility of the installer to ensure that the drive is installed safely and in accordance with any regulations that apply to the end product at the place of use, for example regarding safety or electromagnetic compatibility. To ensure mechanical safety, additional safety devices such as electromechanical interlocks may be required.

Overview of *Comfort+™* C1300 Features and Performance

Anacon Systems' new ***Comfort+™* C1300** motor controllers incorporate digital fan speed control specifically designed for HVAC apparatus. By controlling the fan speed the C1300 drive can save energy, regulate environmental conditions, reduce acoustical noise and improve comfort and convenience.

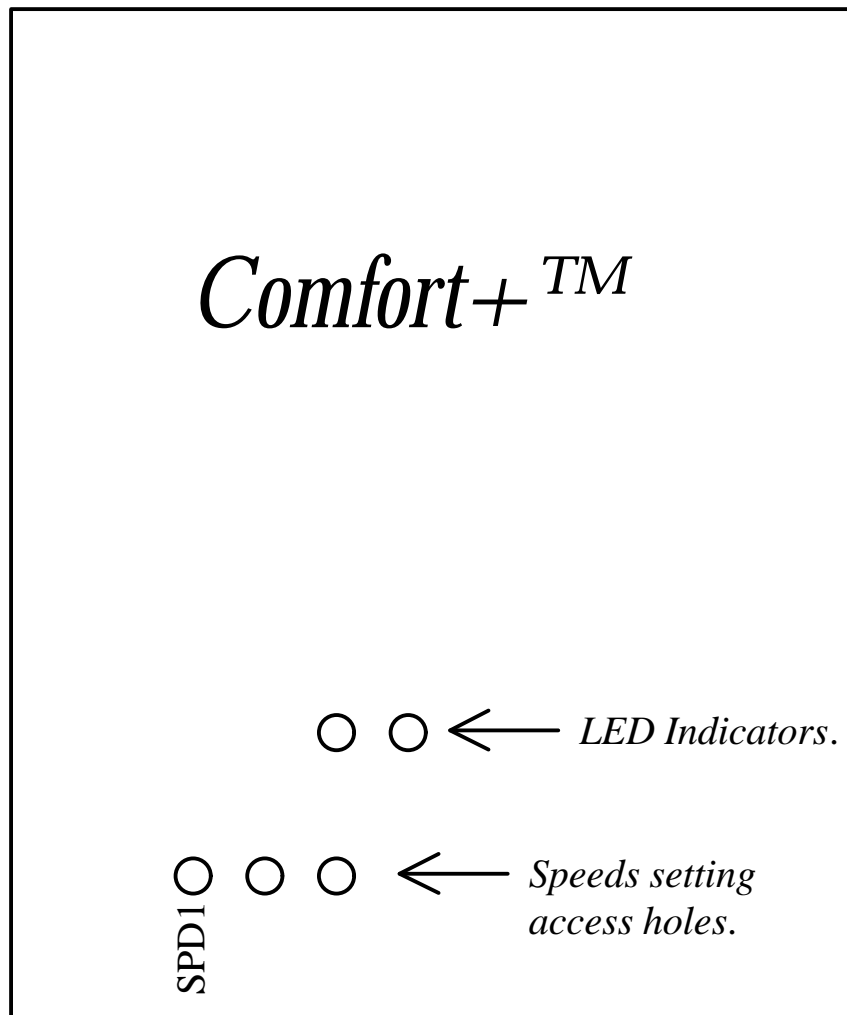

BEFORE *Comfort+* C1300 INSTALLATION

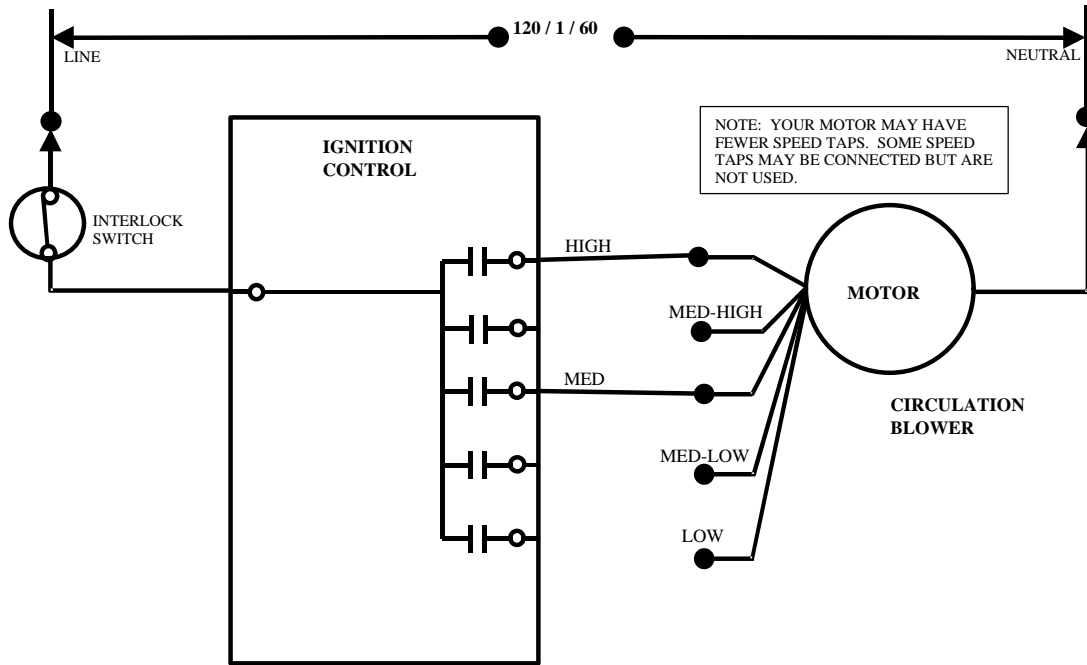

AFTER *Comfort+* C1300 INSTALLATION

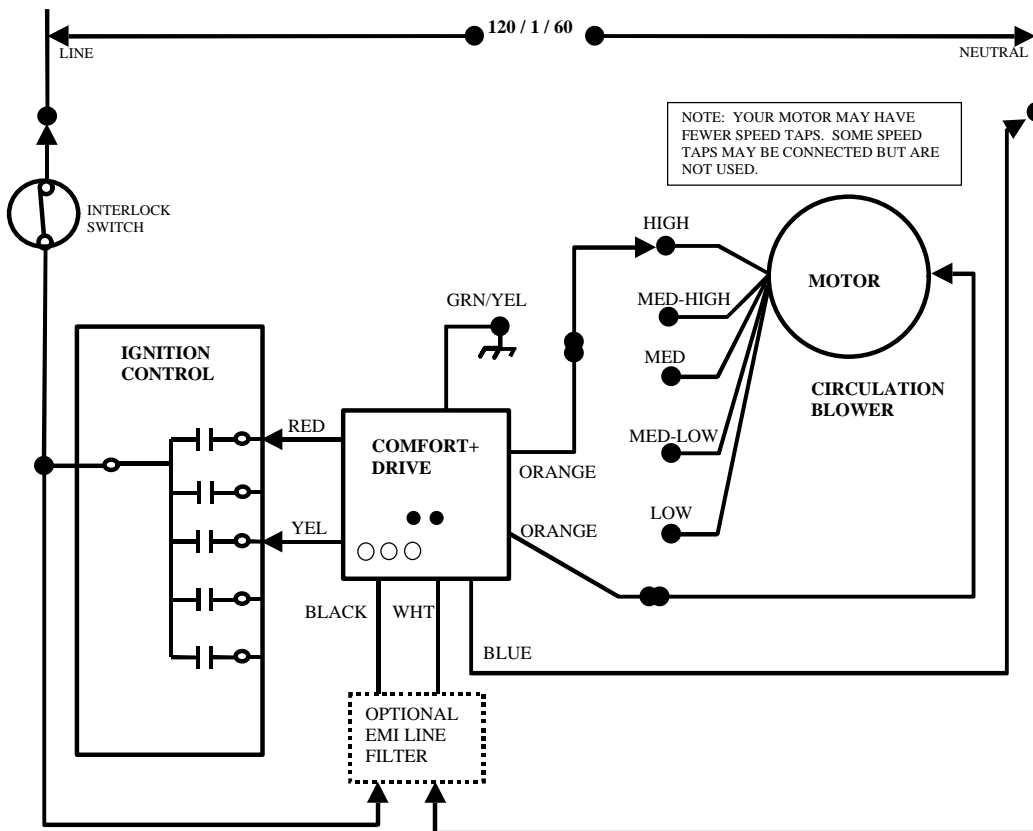

C1300 Power Specifications:

The **C1300** is intended for use on 115 volt PSC type AC induction motors of ½ horsepower or less. The motor’s capacitor size should not exceed the capacitance specified for the motor. This drive is set to trip on over-current at approximately 10.5 amps.

Tools and Parts You May Need:

- Screwdriver
- Insulated or non-conductive tip adjustment screwdriver
- Crimping Tool
- ¼” Female Quick Connects
- ¼” Male Quick Connects
- Ring Terminal for Ground connection
- Wire nuts

C1300 Wiring Chart

Wire Color	Connect To
Black	115 VAC Line
White	115 VAC Neutral
Orange 1	Motor High Speed Winding
Orange 2	Motor Common
Red	Wire previously connected to highest speed motor tap
Yellow	Wire previously connected to lower speed motor tap
Blue	Wire previously connected to motor common
Green/Yellow	Earth Ground

Power Connections:

Note: Wire size is 16 gauge.
 BLACK WIRE: LINE
 WHITE WIRE: NEUTRAL

Motor Connections:

Note: Wire size is 16 gauge.
 1st ORANGE WIRE: MOTOR HIGH SPEED winding tap.
 2nd ORANGE WIRE: MOTOR COMMON lead wire.

Control Connections:

Note: Wire size is 18 gauge.
 RED WIRE: HIGH SPEED command. 110Vac between the RED wire and the BLUE wire selects the speed set by the pot marked SPD1.
 YELLOW WIRE: LOW SPEED command. 110Vac between the YELLOW wire and the BLUE wire selects the speed set by the pot marked SPD2.
 BLUE WIRE: COMMON

Earth/Ground Connection:

Note: Wire size is 16 gauge.
 GREEN/YELLOW WIRE: EARTH/GROUND

Set-up and Operation

Installation:

Mounting Unit: (Refer to *Comfort+* diagram)

1. Turn off power to furnace.

2. Open furnace cabinet where blower motor is located.
3. After checking and verifying power is OFF, determine mounting location for the **Comfort+**. This should be located near the blower preferably in the return air stream. The **Comfort+** should be positioned with the cooling fins in the vertical position and the wire conduit facing downward.
4. Using four self-tapping sheet metal screws (or four nuts and bolts, use hardware that is most appropriate for the unit's location and environment), attach the **Comfort+** chassis to the chosen mounting location. Note: Mount the **Comfort+** unit with the cooling fins in a vertical position.

Connecting *Comfort+*'s Motor Outputs:

1. Identify and record which furnace wiring is connected to which motor speed-winding taps. Disconnect motor wires from furnace system (i.e., High, Medium, Low, and Common). NOTE: If more than two motor windings are connected to the existing controller unit, it is important to determine which motor taps are being used for the furnace's modes of operation (i.e., heating, cooling, fan).
2. Using the High-speed motor winding tap and motor common lead wires, connect to the **Comfort+**'s ORANGE leads (Motor Outputs). There should be two ORANGE wires. IMPORTANT: ATTACH WIRE NUTS (OR EQUIVALENT) TO THE REMAINING UNUSED MOTOR WIRES TO ISOLATE THEM FROM EACH OTHER AND FROM THE SYSTEM. NOTE: KEEP THE TOTAL LENGTH FROM THE DRIVE TO THE MOTOR TO LESS THAN 5 FEET.

Connecting *Comfort+*'s Control Inputs:

1. Connect the furnace wire that was previously connected to the highest speed motor tap to the **Comfort+**'s RED flying lead.
2. Connect the furnace wire that was previously connected to the lower speed motor tap to the **Comfort+**'s YELLOW flying lead. NOTE: Does not apply to units with only one operating speed.
3. Connect the furnace wire that was previously connected to the motor's common to the **Comfort+**'s BLUE flying lead.

Connecting *Comfort+*'s Input Power and Ground:

1. For the **Comfort+** to work properly, the **Comfort+** requires that it be continuously powered when the system is powered. In other words, power should not be cycled on and off with normal system operation. CAUTION: INPUT POWER CONNECTIONS TO THE **Comfort+** SHOULD COME FROM THE OUTPUT SIDE OF THE SAFETY INTERLOCK (IF APPLICABLE).
2. Connect system line power to the **Comfort+**'s BLACK flying lead.
3. Connect system neutral to the **Comfort+**'s WHITE flying lead.
4. Connect the GREEN and YELLOW EARTH GROUND lead wire to the system's earth ground. NOTE: CHECK THAT THE GREEN AND YELLOW EARTH GROUND WIRE IS CONNECTED TO SYSTEM EARTH GROUND!

Operation:

Applying power to the *Comfort+* C1300:

Note: This section may need to be repeated several times in order to obtain proper settings.

1. Turn on power to the furnace system. Note: The furnace may have safety interlocks that require the unit to be closed up before operation. PLEASE OBSERVE ALL SAFETY REQUIREMENTS.
2. Set furnace system control so that the high-speed input command is turned on. (i.e., system call for heat or cool)
3. Check system for proper operation. Checks may include but are not limited to measuring motor rpm, temperature rise and proper airflow.
4. Repeat checks for second speed and idle speed (if used) modes of operation.
5. If motor speed is not correct for either or both speed settings, then power OFF the unit, WAIT 5 MINUTES for residual energy to bleed down from drive, and perform the "Changing the *Comfort+*'s Speeds" section. CAUTION! DO NOT ATTEMPT TO DISCHARGE THE **COMFORT+**'s RESIDUAL ENERGY. THIS MAY RESULT IN DAMAGING THE DRIVE, PERSONAL INJURY OR EVEN DEATH. SEE WARNINGS ABOVE!

6. If motor speeds are OK then go to the “**Testing the System**” section.

Changing the C1300 Speeds:

Caution: When making adjustments to the idle or speed potentiometers, use an insulated or non-conductive tip screwdriver. Refer to the diagram at the beginning of this manual for proper access to the IDLE, SPD2, and SPD1 potentiometers.

Note: SPD1 should be used for the higher speed mode of operation.

Note: SPD2 should be used for the lower speed mode of operation.

Note: IDLE should be set lower than SPD2 speed.

Note: This section may need to be repeated several times in order to obtain proper operating speeds.

1. The factory set default speeds are 60 Hz for the RED wire (SPD1) and 40 Hz for the YELLOW wire (SPD2).
2. Turning the appropriate potentiometer in the clockwise (CW) or counter-clockwise (CCW) directions makes speed adjustments. To increase speed, turn the potentiometer in the CW direction. To decrease speed, turn the potentiometer in the CCW direction. Note: Typically only small adjustments are necessary to change the drives output frequency. For example, turning the potentiometer one-tenth of a turn will change the speed by approximately 15 to 20%. Increase or decrease accordingly, potentiometer SPD1 (R1), SPD2 (R2), and IDLE (R5) to obtain desired speed.
3. When making adjustments, allow the drive approximately 10 seconds to respond to the change. This is normal operation.
4. Repeat the “**Applying power to Comfort+ C1300**” section.

Multi-Function IDLE Speed Operation:

Caution: When making adjustments to the idle or speed potentiometers, use an insulated or non-conductive tip screwdriver.

The idle speed potentiometer has been designed with three modes of operation to give you greater flexibility in how your system operates when your furnace is not heating or cooling. It allows your system to move air at an “idle” or “destratification” speed when, otherwise, the blower would normally be off (i.e. when neither of the HIGH (RED) and LOW (YELLOW) speed selects has ac power). Note: This feature will only work if the thermostat fan is set to the OFF position.

If the thermostat is set to the “Fan On” position, the blower will operate at either the SPD1 setting or SPD2 setting.

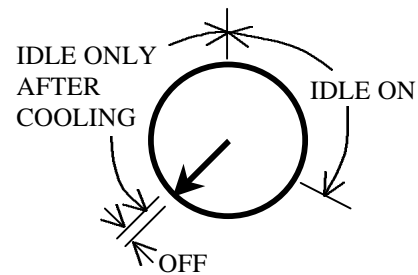

The idle function is factory preset to OFF. The three modes of operation are:

IDLE OFF: To turn the idle run feature off, rotate the idle speed pot fully counter-clockwise (CCW). The idle function will be disabled and blower will not run except when heating or cooling.

IDLE ONLY AFTER COOLING: Idle after cooling mode is set in the first half rotation of the idle pot. Turn the idle pot clockwise (CW) to set idle speed. This allows your system to run at the set idle speed but only following a system cooling cycle. This feature is good for the summer season when temperature de-stratification and air circulation is desired between cooling periods. Note: If you go beyond the first half rotation of the idle pot when setting the idle speed, the red LED will blink at a rate of two times a second indicating the idle on mode setting.

IDLE ON: Idle on mode is set in the second half of the idle speed pot. Set the idle on by turning the idle pot CW beyond the first half turn until the red LED begins to blink at a rate of two times per second. Then adjust the to the desired idle speed above where the red LED begins blinking. This feature allows you to run the blower continuously for de-stratification, air circulation and filtering between heating and cooling cycles.

System Resonance:

This is the condition when the frequency applied to the motor equals a natural frequency of the furnace system. The system will vibrate and make noise at its resonant frequency. Even though all systems have natural frequencies that can be exploited by variable frequency drives, Anacon Systems has developed the **Comfort+’s** control algorithms to greatly minimize or even eliminate the effects of resonance occurring.

If your system experiences resonance noise during its operation, in most cases this can be resolved. For a given HEAT, COOL, or IDLE mode where the resonance occurs, adjusting the speed set point slightly higher or lower should result in the noise disappearing or being greatly reduced. CAUTION: If you are making adjustments to the HEAT or COOL settings make sure the furnace is within its temperature and airflow specifications, respectively.

An unbalanced blower wheel may cause excessive vibration and noise. If you suspect an unbalanced blower wheel condition, please have the blower unit checked and rebalance.

Testing the System:

A check of the system’s operating modes must be performed at this point.

Heating:

1. Replace the blower access panel.
2. Set the thermostat to heat and turn up the temperature setting until the furnace turns on.
3. Verify after any system delay relays or timers that the **Comfort+** ramps up to the desired speed setting.
4. Verify furnace heat rise is within the furnace manufacturer’s specifications. Refer to the furnace manufacturer’s operating and installation specifications for proper operating temperatures.
5. If not set properly, repeat “**Changing the C1300 Speeds**” section to make adjustments.

Cooling:

1. Set the thermostat to cool and turn down the temperature setting until the AC turns on.
2. Verify after any system delay or timers that the **Comfort+** ramps to the desired speed setting.
3. Verify proper airflow through the system to avoid freezing the condenser coil and condensate blow-off. Refer to the manufacturer’s operating and installation specifications for proper operating airflows.
4. If not set properly, repeat “**Changing the C1300 Speeds**” section to make adjustments.

LED Status Indicators:

GREEN LED ON: Unit is powered and properly operating.

RED LED ON: Red LED on means that the controller experienced an over-current condition or other fault condition. Please reread this installation manual to verify that the **Comfort+** has been installed correctly and refer to the “**Trouble-Shooting**” section. To reset the **Comfort+** drive, Power will need to be cycled OFF and then back on. If this fault indicator continues to come on, please contact your distributor.

Trouble-Shooting:

The Green LED light is not on at all.	Check the AC input power connection for AC voltage.
	Check the system interlock switch.
The Red LED light is on.	Check the motors ratings and make sure they do not exceed the ratings of the drive.
	Verify the motor is a Permanent Split Capacitor or Shaded Pole motor. If you are connecting to any other type of motor please contact your distributor for technical assistance.
Green LED is on but the motor does not run.	Check the control input commands for proper AC input voltages.
	Check the speed adjustment settings. Is the speed setting set high enough to turn the motor?
There is a vibration or humming noise coming from my unit.	Check which speed setting is on (i.e., idle, spd1, or spd2) and try adjusting that speed setting slightly higher until the noise is reduced or eliminated.

Drive Specifications:

Electrical Characteristics

Definition	Symbol	Typ.	Min.	Max.	Units	Notes
Input Voltage (rms)	V _{IN}	115	93	138	VAC	Single-phase
Input Current (rms)	I _{IN}			10	A	At 100% load, V _{in} =115
Input Frequency	F _{IN}	60	45	65	Hz	
Output Power (rms)	P _o		0	740	W	
Output Voltage	V _o		0	V _{in}	VAC	Variable with frequency
Output Current (min. 50 CFM air over)	I _o			8	A	rms current
Output Current (No air over)	I _o			5	A	rms current
Output Frequency	f _o		1	65	Hz	Factory set
Control Input Voltage (On)	CV _{on}	115	90	230	VAC	
Control Input Voltage (Off)	CV _{off}	0	10		VAC	
Frequency Resolution		0.5			Hz	
PWM Switching Frequency	f _{sw}	18			kHz	
Ramp Times				40	S	Factory set
Ambient Operating Temperature	T _a	25	0	40	deg C	
Ambient Storage Temperature	T _{stg}	25	0	65	deg C	
Humidity Range	H	60	0	95	%	Non-condensing

	W	H	L	Units	
Dimensions	6	6	2.8	in.	NEMA 1 Enclosure

Corporate Headquarters

Address: 1043 Shoreline Blvd., #202
 Mountain View, CA 94043
 Tel: (650) 934-3355
 Fax: (650) 934-3356



Sales and Application Center

Address: Crystal Mountain Office Park
 9433 Bee Cave Road
 Building 1, Suite 140
 Austin, TX 78733
 Tel: (512) 263-8668, (888) 456-3398
 Fax: (512) 263-8060

European Headquarters:

Address: Saville Court, Saville Place
 Clifton, Bristol BS8 4EJ,
 United Kingdom

Email – info@anaconsystems.com

Website – www.anaconsystems.com